

Raffaello LINE

 **Benelli**

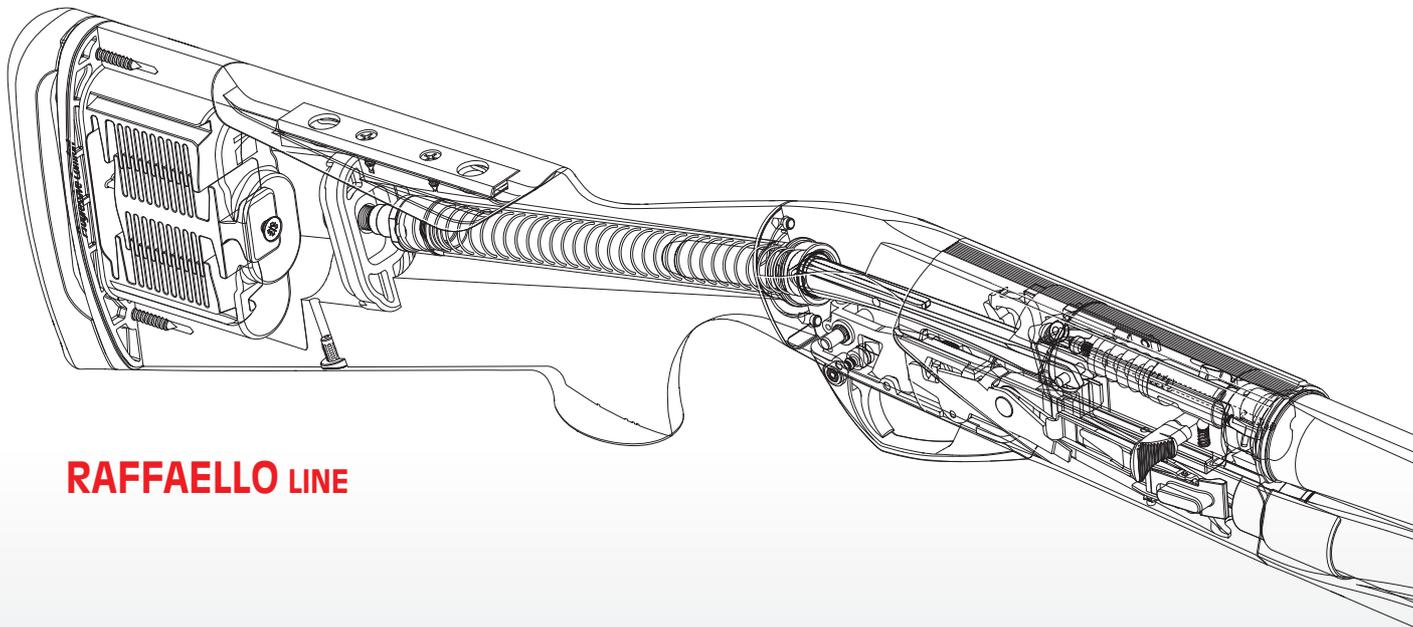

RAFFAELLO LINE

 **Benelli**



Index



USE • MAINTENANCE	1
Basic safety rules	2
Introduction	4
Operation	4
Assembly	6
Gun safety catch	7
Loading	8
Cartridge replacement	9
Unloading	10
Troubleshooting	11
Ammunition	11
Maintenance	11
Shotgun stripping	12
Shotgun assembly	15

ACCESSORIES AND ADJUSTMENTS:

Drop and cast adjustments	17
Internal choke	18
Interchangeable ribs	20
Changing the front sight	20
Fitting the sling attachment pin to the stock	21
Removing and changing the comb	21
Adjusting the rear sight (when fitted)	22
Adjusting the rear sight for windage	22
Adjusting the rear sight for elevation	22

SPARE PARTS	23
--------------------------	----



BASIC SAFETY RULES

WARNING: PLEASE READ THIS MANUAL BEFORE HANDLING YOUR FIREARM.

WARNING: FIREARMS CAN BE DANGEROUS AND CAN POTENTIALLY CAUSE SERIOUS INJURY, DAMAGE TO PROPERTY OR DEATH, IF HANDLED IMPROPERLY. THE FOLLOWING SAFETY RULES ARE AN IMPORTANT REMINDER THAT FIREARM SAFETY IS YOUR RESPONSIBILITY.

1. NEVER POINT A FIREARM AT SOMETHING THAT IS NOT SAFE TO SHOOT.

Never let the muzzle of a firearm point at any part of your body or at another person. This is especially important when loading or unloading the firearm. When you are shooting at a target, know what is behind it. Some bullets can travel over a mile. If you miss your target or if the bullet penetrates the target, it is your responsibility to ensure that the shot does not cause unintended injury or damage.



2. ALWAYS TREAT A FIREARM AS IF IT WERE LOADED.

Never assume that a firearm is unloaded. The only certain way to ensure that a firearm has the chamber empty is to open the chamber and visually and physically examine the inside to see if a round is present. Removing or unloading the magazine will not

guarantee that a firearm is unloaded or cannot fire. Shotguns and rifles can be checked by removing all rounds and by then opening and inspecting the chamber so that a visual inspection of the chamber for any remaining rounds can be made.

3. STORE YOUR FIREARM SO THAT CHILDREN CANNOT GAIN ACCESS TO IT.

It is your responsibility to ensure that children under the age of 18 or other unauthorized persons do not gain access to your firearm. To reduce the risk of accidents involving children, unload your firearm, lock it and store the ammunition in a separate locked location. Please note that devices intended to prevent accidents - for example, cable locks, chamber plugs, etc., - may not prevent use or misuse of your firearm by a determined person. Firearm storage in a steel gun safe may be more appropriate to reduce the likelihood of intentional misuse of a firearm by an unauthorized child or person.

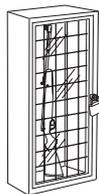

4. NEVER SHOOT AT WATER OR AT A HARD SURFACE.

Shooting at the surface of water or at a rock or other hard surface increases the chance of ricochets or fragmentation of the bullet or shot, which can result in the projectile striking an unintended or peripheral target.



5. KNOW THE SAFETY FEATURES OF THE FIREARM YOU ARE USING, BUT REMEMBER: SAFETY DEVICES ARE NOT A SUBSTITUTE FOR SAFE HANDLING PROCEDURES.

Never rely solely on a safety device to prevent an accident. It is imperative that you know and use the safety features of the particular firearm you are handling, but accidents can best be prevented by following the safe handling procedures described in these safety rules and elsewhere in the product manual.

To further familiarize yourself with the proper use of this or other firearms, take a Firearms Safety Course taught by an expert in firearms use and safety procedures.

6. PROPERLY MAINTAIN YOUR FIREARM.

Store and carry your firearm so that dirt or lint does not accumulate in the working parts. Clean and oil your firearm, following the instructions provided in this manual, after each use to prevent corrosion, damage to the barrel or accumulation of impurities which can prevent use of the gun in an emergency. Before loading your firearm, always check the barrel internal part and the chamber to ensure that they are clean and free from obstructions. Firing with an obstruction in the barrel or chamber can rupture the barrel and injure you or others nearby. In the event you hear an unusual noise when shooting, stop firing immediately, engage the manual safety and unload the firearm.



Make sure the chamber and barrel are free from any obstruction, like a bullet blocked inside the barrel due to defective or improper ammunition.

7. USE PROPER AMMUNITION.

Only use factory-loaded, new ammunition manufactured to industry specifications: CIP (Europe and elsewhere), SAAMI® (U.S.A.). Be certain that each round you use is in the proper caliber or gauge and type for the particular firearm.

The caliber or gauge of the firearm is clearly marked on the barrels of shotguns and on the slide or barrel of pistols.

The use of reloaded or remanufactured ammunition can increase the likelihood of excessive cartridge pressures, case-head ruptures or other defects in the ammunition that can cause damage to your firearm and injury to yourself or others nearby.

8. ALWAYS WEAR PROTECTIVE GLASSES AND EARPLUGS WHEN SHOOTING.

The chance that gas, gunpowder or metal fragments will blow back and injure a shooter who is firing a gun is rare, but the injury that can be sustained in such circumstances can be severe, including the possible loss of eyesight. A shooter must always wear impact resistant shooting glasses when firing any firearm. Earplugs or other high-quality hearing protectors help reduce the chance of hearing damage from shooting.



9. NEVER CLIMB A TREE, FENCE OR OBSTRUCTION WITH A LOADED FIREARM.

Open and empty the chamber of your firearm and engage the manual safety catch before climbing or descending a tree or before climbing a fence or jumping over a ditch or other obstruction. Never pull or push a loaded firearm toward yourself or another person. Always unload the firearm, visually and physically check to see that the magazine, loading mechanism and chamber are unloaded and that the bolt is open before handing the firearm to another person. Never take a firearm from another person unless it is unloaded, visually and physically checked to confirm it is unloaded, and the action is open.



10. AVOID ALCOHOLIC BEVERAGES OR JUDGMENT/ REFLEX IMPAIRING MEDICATION WHEN SHOOTING.

Do not drink and shoot. If you take medication that can impair motor reactions or judgment, do not handle a firearm while you are under the influence of the medication.



11. NEVER TRANSPORT A LOADED FIREARM.

Unload a firearm before putting it in a vehicle (chamber empty, magazine empty). Hunters and target shooters should load their firearm only at their destination, and only when they are ready to shoot. If you carry a firearm for self-pro-



tection, leaving the chamber unloaded can reduce the chance of an unintentional discharge.

12. LEAD WARNING.

Discharging firearms in poorly ventilated areas, cleaning firearms, or handling ammunition may result in exposure to lead and other substances known to cause birth defects, reproductive harm, and other serious physical injury. Have adequate ventilation at all times. Wash hands thoroughly after exposure.

WARNING: it is YOUR responsibility to know and abide by Federal, State and Local laws governing the sale, transportation and use of firearms in your area.

WARNING: this firearm has the capability of taking your life or the life of someone else! Always be extremely careful with your firearm. An accident is almost always the result of not following basic firearm safety rules.

Especially for U.S. consumers:

For information about Firearm Safety Courses in your area, please visit the National Rifle Association's web site at www.nra.org.





Introduction

Benelli Armi is proud to present the new Raffaello. Its exclusive technology and significantly restyled looks have been especially chosen to allow Benelli Armi's most popular family of shotguns to establish itself as a true hunting classic with a modern, high-tech heart.

Thanks to the constant commitment of Benelli Armi's Research and Development Centre, the new Raffaello incorporates Benelli's superb and innovative Progressive Comfort system in addition to all the usual benefits of Benelli shotguns.

The Progressive Comfort system is the only recoil damping system for wooden stocks that adapts its action to match the power of the cartridges used and damps recoil progressively. The Progressive Comfort stock combines with the comb to form the Benelli Full Comfort system.

The new Raffaello sets the highest standards and represents a truly precious addition to Benelli's vast range of firearms.

Operation

The new "Benelli" semi-automatic shotguns operate on the same basic principle of **inertial operation, with fixed barrel**, utilizing the kinetic energy of gun recoil, today still the most important, ingenious feature of our guns.

As you know, this system requires no outlet for gas or barrel recoil, but operates by means of a spring freely interposed between bolt head and bolt.

During firing, due to the recoil of the gun, the (inert) bolt moves about 4 mm forward, in relation to the power of the cartridge, compressing the spring.

When this is fully compressed, it extends, making the whole bolt assembly move back, thus permitting the cartridge case extraction and the gun reloading according to the conventional system.

Spring pressure is designed to delay the opening of the action and regulate the different pressures produced by cartridges of varying power, with no need for braking.

We have added to this system a simple shape and robust **rotating bolt head** which with only 2 locking teeth, closes the breech axially and perfectly, withstanding any pressure of the cartridge.

The new line of shotguns features a loading system designed to:

- make it possible to shift cartridge manually from the magazine tube to the barrel for quick and easy ammunition changes;
- ensure even faster and safer automatic re-loading;
- check whether the hammer is cocked and ready to shoot.

The new loading system features a special cartridge drop lever, the outer portion of which protrudes below the receiver and is thus easily reached by the trigger finger.



Upon shooting, the hammer spring forces the cartridge drop lever upwards to disengage it from the carrier latch which, pulled by the carrier latch spring, rotates clockwise to allow a cartridge to exit from the magazine.

As the cartridge falls into position on the carrier, it presses against the carrier latch, which rotates in the opposite direction to prevent a second cartridge from exiting.

When the bolt is operated the carrier rises automatically to position the cartridge for introduction in the chamber.

In the meantime, the hammer spring, which was compressed during cocking, has freed the cartridge drop lever to return to its rest position. In this way, the carrier latch is obliged to hold the remaining cartridges in the magazine until the next shot is fired.

The end of the cartridge drop lever which protrudes from the receiver is marked with a red point.

When the red point is visible, the hammer is cocked and the gun is ready to fire; otherwise the hammer is not cocked.

Like all Benelli automatic shotguns, the fully automatic operation of the new shotguns depends on its recoil.

This eliminates the drawbacks of the systems with barrel recoil (barrel vibration during firing, need to brake the system and regulate it when firing powerful ammunition etc.) and those of the gas operated type (need to clean gas outlets, loss of power due to acceleration of the shot charge and adverse effect on the longitudinal conformation of the wad and possible malfunctions under adverse climatic conditions), producing a modern, highly reliable gun.

The new semi-automatic shotguns work with a vast range of shells.

The inertia system requires, in any case, shells that generate enough kinetic energy (recoil) to fully cycle the action.

The vast experience of our ballistic laboratory and extensive field testing have allowed us to establish exactly the right parameters needed to ensure the correct functioning of your shotgun. In particular, we have determined **200 kgm** as the minimum kinetic energy required from a **12 gauge cartridge** (measured at 1 m from the muzzle of a manometric barrel).

WARNING: at the minimum kinetic energy stated above, correct functioning is only guaranteed for a shotgun with a **MAXIMUM** total weight of 3.150 kg.



KEY TO ARROW COLOURS

<i>colour</i>	<i>description</i>
red	stripping sequence
green	assembly sequence
blue	location
yellow	action



Assembly (from packaged gun)

Components of the package (fig. 1):

- a) stock-receiver-bolt-fore-end unit
- b) barrel-breech unit

WARNING: please remember to remove the **plastic barrel sheath** before using the firearm (fig. 2).

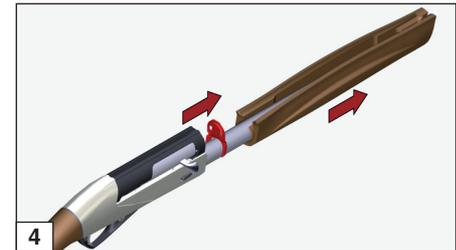
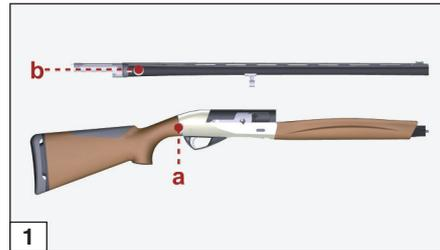

Assembly procedure

- 1) Unscrew the **fore-end cap** (fig. 3).
- 2) Remove the **fore-end** and remove the packaging plate (fig. 4).
- 3) Hold the **stock-receiver-bolt** assembly in one hand. Place the other hand on the cocking lever and open the **bolt** until it locks (fig. 5).

WARNING: should the bolt **fail** to engage, **move the cartridge drop lever** as arrowed and repeat the operation (fig. 6).

*During this operation the **bolt group** should be completely assembled and placed **in the receiver, in open position** (backward).*

- 4) Hold the bolt cover steady with respect to the receiver with one hand. Grip the **barrel-breech** unit with the other hand.

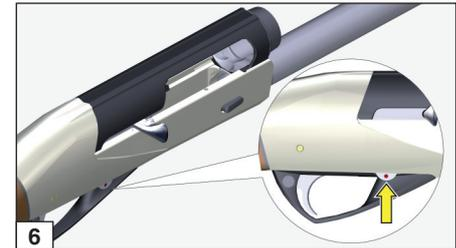
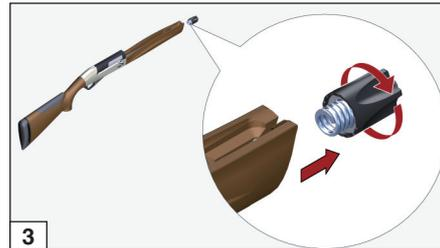
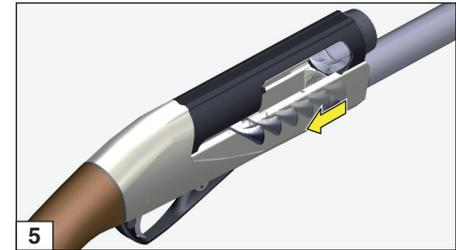



- Slide the breech **extension** into the receiver making sure that the **barrel ring** slides on the **magazine tube** (fig. 7).
- Push the barrel-breech assembly all the way in (fig. 8) until it clicks into place and is firmly seated.

NOTE: make sure that the breech **extension** does not collide against the bolt locking head but rather that it fits between the cover and the locking head.

- Slide the **fore-end** over the magazine tube (fig. 9).
- Screw the **fore-end cap** on to the end of the magazine tube and **tighten it** sufficiently to hold the barrel and fore-end securely against the receiver (fig. 10).

NOTE: always make sure that the cap **spring** is **inserted in the cap** itself (fig. 10) before locking the barrel and fore-end to the receiver: a missing spring will **not allow** proper locking of the barrel, **causing serious damage to the shotgun.**

- Press the **carrier button** to close the **bolt** (fig. 11).

Gun safety catch

Press the **safety button** on the trigger guard until its **red ring**, indicating firing position, is **no longer visible** (fig. 12).

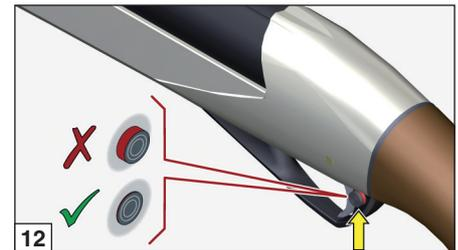
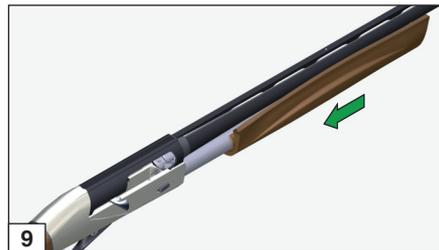
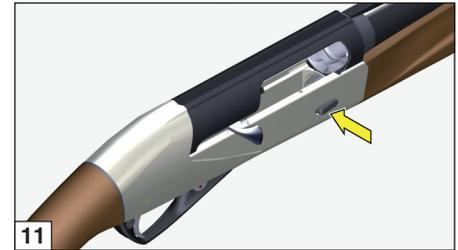
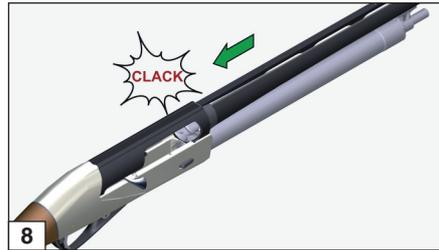
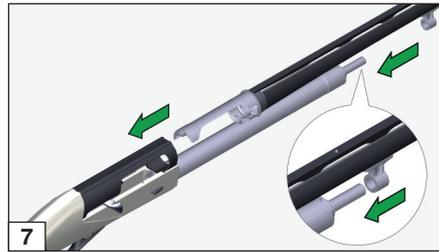



Loading

Before starting any operation on your shotgun, make sure that the chamber and the magazine are unloaded!

(Carefully read the instructions on gun loading and unloading).

NOTE: make sure that your firearm is fitted with a magazine tube containing a number of cartridges permitted by legislation in the country where you intend to use it.

Loading procedure

NOTE: make sure that the shotgun **safety** catch (see “Gun safety catch”) is engaged and the **hammer cocked** (so that the carrier latch can retain the cartridges as they are inserted in the magazine).

WARNING: for safety reasons, **check** if by opening the bolt the shotgun is unloaded. Then **close** the bolt **again**.

- 1) Make sure that the **red dot** on the cartridge drop lever (indicating that the hammer is cocked) is **clearly visible** (fig. 13). If it is not, press the **carrier button (a)**, open the **bolt (b)** then close the bolt again **(c)** (fig. 14).
- 2) With the bolt closed and the hammer cocked, reverse the gun **pointing the barrel downwards**.

- 3) **Insert a cartridge** into the magazine (fig. 15): push it until it is retained by the carrier latch which engages automatically (fig. 16). Repeat the operation until the magazine is fully loaded.

NOTE: the gun must be loaded with the **hammer cocked** so that the carrier latch can retain the cartridges as they are inserted in the magazine.

Now the gun cannot be fired unless a **cartridge is placed in the barrel**, as to one of the following procedures:

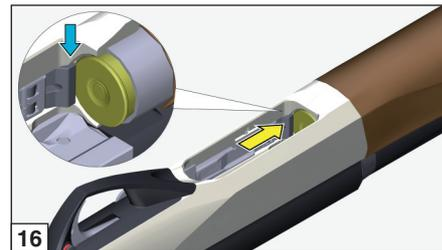
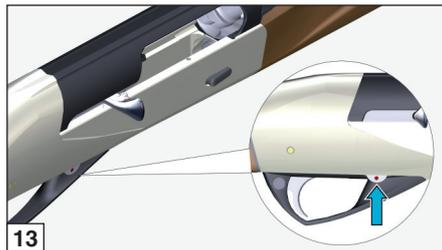
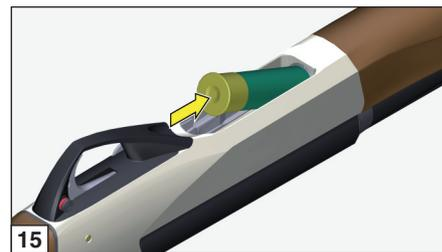
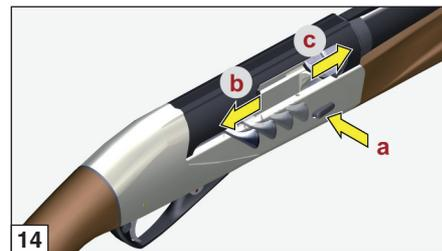



Direct procedure (figs. 17-18):

- 1) **Open the bolt** and at the same time insert a cartridge into the barrel through the case ejection port.
- 2) **Release the cocking lever:** the bolt will push the cartridge on the carrier into the chamber and stop in the closed position.

Indirect procedure (fig. 19):

- 1) Open the bolt (**a**) and hold it open. Press the **cartridge drop lever (b)** to allow the first cartridge to drop on to the carrier.
- 2) **Release the bolt (c).** The bolt will slide forward, chambering the cartridge and locking in closed position.

WARNING: the “indirect” loading method reduces the number of rounds in the magazine by one. An additional cartridge can, however, be inserted as described above to fill the magazine completely.

NOTE: during this operation, always **point the gun in a safe direction**, even though the safety catch is engaged (see “Gun safety catch”).

Now the **gun is loaded:** when the safety catch is moved to firing position (**red ring visible**), the gun is ready for use.

WARNING: when your shotgun is new and before beginning to use it normally, a breaking-in period may be required before your new shotgun works perfectly with light target loads. If you experience any initial functioning pro-

blems, we recommended firing three or four boxes of **standard hunting** loads to allow for this break-in period.

Cartridge replacement

(This operation must be carried out with the gun safety catch engaged - see “Gun safety catch” and barrel pointed in a safe direction)

To replace a cartridge in the chamber, two procedures can be followed:

- by manual replacement of a new cartridge;
- by using the cartridge drop lever.

Manual replacement (when the cartridge is not coming from the magazine)

- 1) Rest the stock on your hip and pull the cocking lever to open the **bolt**: the cartridge in the chamber is extracted and ejected from the gun (fig. 20).

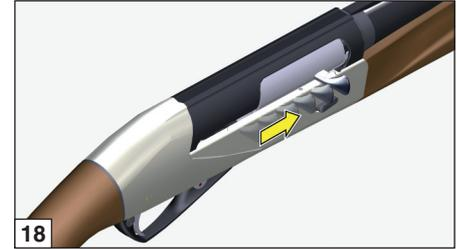

18

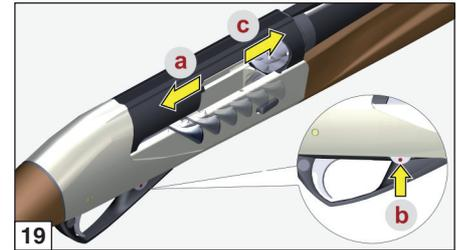

19

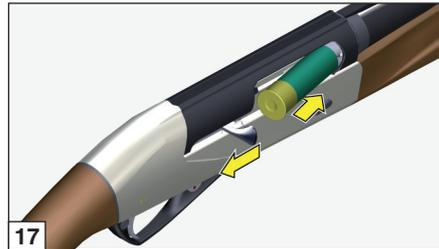

17

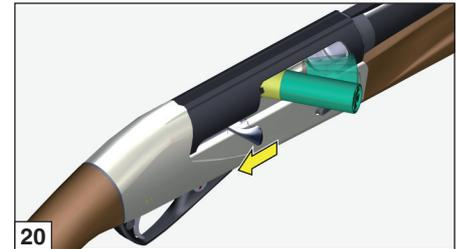

20



- 2) Insert a new cartridge even partially in the barrel through the special ejection window (fig. 21) and release the cocking lever to close the bolt again.

Using the cartridge drop lever (when the cartridge is coming from the magazine)

- 1) Rest the stock on your hip and pull the cocking lever to open the **bolt**: the cartridge in the chamber is extracted and ejected from the gun (fig. 20).
- 2) Press the **cartridge drop lever** (fig. 22) and release the cocking lever to close the bolt again. In this way, the cartridge will pass quickly from the magazine to the chamber.

WARNING: the shotgun can also be unloaded by repeatedly operating the cartridge drop lever as instructed in the **“Cartridge replacement”** section.

Unloading

(This operation must be carried out with the gun safety catch engaged - see **“Gun safety catch”** and the barrel pointed in safe direction)

To unload the shotgun, proceed as follows:

- 1) **Open the bolt:** the cartridge in the chamber will be extracted and ejected (fig. 23).
- 2) **Close the bolt:** gently releasing the cocking lever (fig. 24).
- 3) Reverse the gun and - thrusting the carrier towards inside - **press** the **carrier latch** frontal part with your index finger (fig. 25); the first cartridge will come out. Repeat this procedure for each cartridge you want to remove from the magazine.

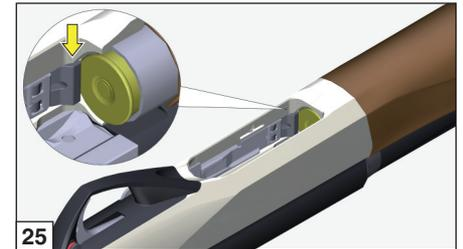
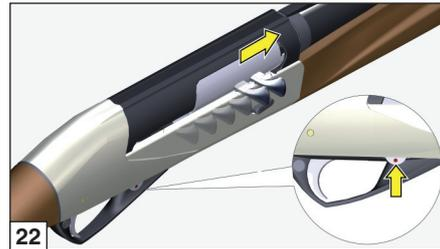
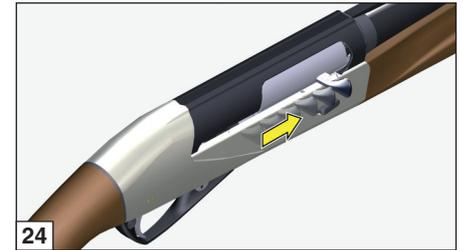
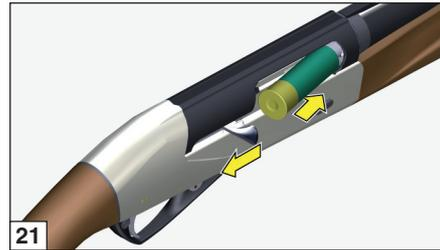
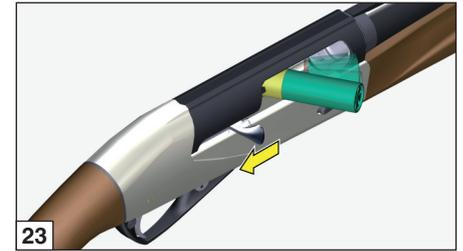

Troubleshooting

Before starting any operation on your shotgun, make sure that the chamber and the magazine are unloaded!

(Carefully read the instructions on gun loading and unloading).

The gun fails to fire

- 1) **Check the safety catch:** if it is engaged, push the button to the fire position.
- 2) **Check that there is a cartridge in the barrel.** If necessary, insert a cartridge following the loading instructions (page 8).
- 3) **Check the firing mechanism.** If necessary, clean and lubricate it.

Fore-end cap

Check that the fore-end **cap** is fitted **with spring** and, especially after the first rounds, check that it is tightened firmly, to keep the **barrel** firmly against to the receiver.

Ammunition

Benelli shotguns use the kinetic energy generated by the recoil to work the action.

Use always ammunition that is powerful enough to fully cycle the action.

WARNING: when your shotgun is new and before beginning to use it normally, a breaking-in period may be required before your new gun

works perfectly with light target loads. If you experience any initial functioning problems, we recommended firing three or four boxes of **standard hunting cartridges**.

Choice of ammunition

Correct functioning of the shotgun is only guaranteed with cartridges of a maximum length of **58 mm** (2" 3/4 - 70 mm chamber) or **66 mm** (3" - 76 mm chamber). The shotgun accepts cartridges with rolled turnover or crimped closures, and with lead or steel shot.

Benelli recommends use of shot loaded ammunitions for ribbed barrels and balls for slug barrels.

This is not mandatory but will ensure top-notch performance.

CAUTION: never use cartridges with a case **longer** than the chamber.

Non-compliance to this rule would have serious consequences for both the shotgun and the shooter.

No adjustment to the shotgun is necessary to fire any of the ammunition listed above.

Always use ammunition that is powerful enough to fully cycle the action.

All Benelli shotguns are subjected to a 1370 bar burst test at the Italian National Proof House in Gardone Valrompia (Brescia).

Maintenance

Before starting any operation on your shotgun, make sure that the chamber and the magazine are unloaded! (Carefully read the instructions on gun loading and unloading).

Thanks to its extreme simplicity and excellent materials, the Benelli Automatic Shotgun **requires no** special maintenance.

The following few controls **are recommended:**

- 1) normal cleaning of the **barrel** after use;
- 2) the firing mechanism, consisting of hammer, trigger, etc., may become clogged with **any powder residuals** (or foreign matters). Remove them by periodical cleaning or lubrication;
- 3) the **bolt assembly** may also become clogged with the same residuals over mentioned and therefore must be periodically dismantled, cleaned and lubricated;
- 4) to keep the gun in good order, oiling of the **parts subject** to atmospheric corrosion is recommended.

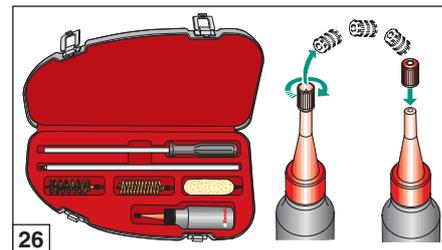



NB: all barrels are internally **chromium plated**.

NOTE: when cleaning a barrel with an internal choke fitted, leave the choke in place to prevent powder residues from fouling the threads inside the muzzle.

For a proper maintenance of your firearm, use **Benelli cleaning kit** (not supplied).

Benelli oil is recommended for lubricating and protecting mechanical parts (receiver, bolt and barrel) (fig. 26).

Benelli recommends use of specific products for cleaning other parts (wooden, technopolymer and camouflage or painted stock and fore-end). Avoid that parts get in contact **with oils containing solvents or chemical substances in general, which could alter or damage their surfaces.**

Shotgun stripping

(for cleaning and maintenance)

Before starting any operation on your shotgun, make sure that the chamber, carrier and the magazine are unloaded!

(Carefully read the instructions on gun loading and unloading).

WARNING

(for models where ShellView is available)

Even though the ShellView allows you to see if your gun magazine is empty, please be advised that while the magazine may seem to be empty to the eye, this does not guarantee that the gun is completely unloaded (fig. 27). Always physically and visually check the magazine and chamber to verify that the firearm is not loaded. Please always follow all the Safety Rules given in this manual.



28

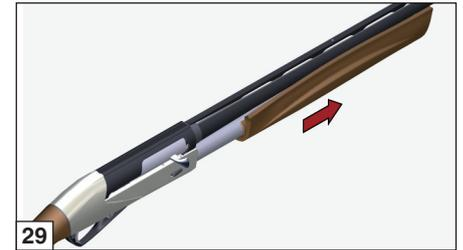

29

- a Benelli ShellView in the fore-end
- b cartridges still in the magazine
- c cartridge missing

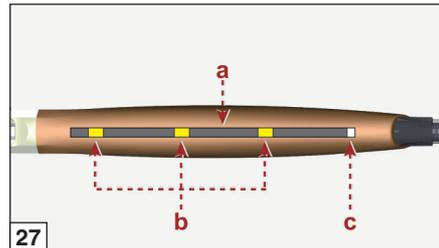

27

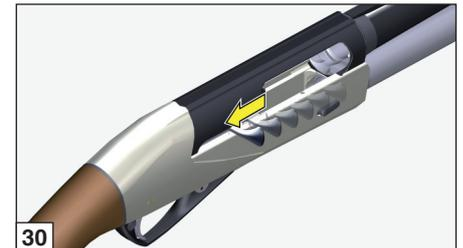

30



Stripping procedure

- 1) Unscrew the fore-end **cap** and remove the **fore-end** making it slide forward along the magazine tube (figs. 28-29).
- 2) Take the gun in one hand and with the other open the **bolt** (fig. 30); should the bolt fail to engage, move the **cartridge drop lever** as arrowed and repeat the operation (fig. 31).
- 3) While resting the shotgun on your hip, keep it with one hand so that the **cover** remains fixed to the receiver and with the other hand pull the **barrel-breech** assembly out of the receiver (fig. 32).
- 4) Pull the **cocking lever** off with a firm tug (fig. 33).
- 5) Separate **the cover** from the receiver, pulling it forward from the bolt assembly (fig. 34).
- 6) While holding the **bolt assembly** with one hand (fig. 35) so as to counter-balance the thrust of the recoil spring, push the **carrier button** and ease the bolt forward until the recoil spring no longer pushes it forward.
- 7) Pull the **bolt assembly** out of the receiver, sliding it along its guides (fig. 36).

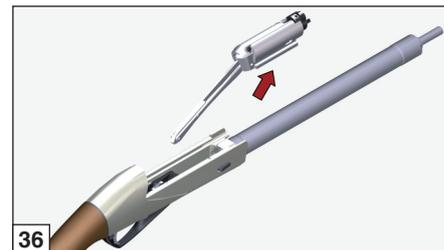
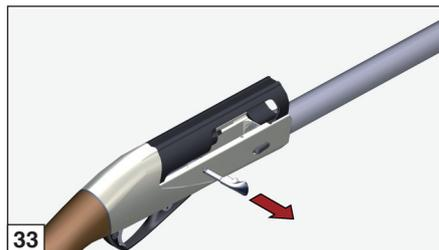
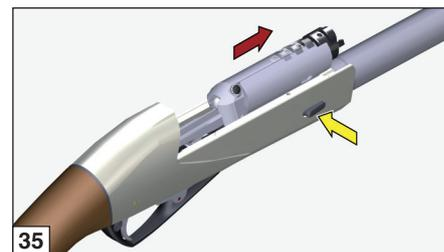
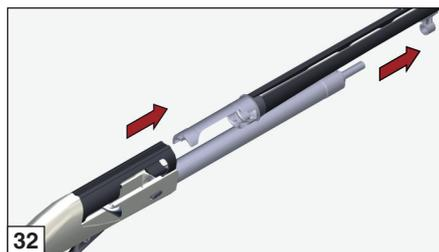
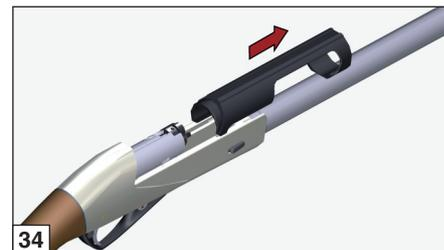
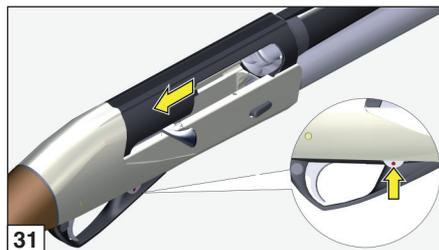



- 8) Remove the **firing pin retaining pin** from the bolt assembly, while **holding** the firing pin and firing pin spring in place (fig. 37).
- 9) Remove the firing pin and firing pin **spring** from the bolt (fig. 38).
- 10) Remove the locking head rotating **pin** from its seat (fig. 39).
- 11) Remove the **bolt locking head** from the bolt (fig. 40).
- 12) Remove the **recoil spring** from its seat in the bolt (fig. 41).
- 13) Extract the **trigger guard pin** from the stock-receiver unit, thrusting it from right or left with the point of the same firing pin or punch (fig. 42).
- 14) **Press** the carrier button and **extract** the trigger guard assembly towards the front (fig. 43).

The shotgun is now completely stripped. All the parts that require routine maintenance and cleaning are disassembled.

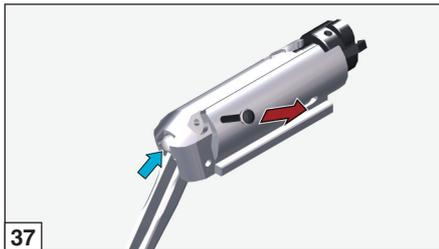

37

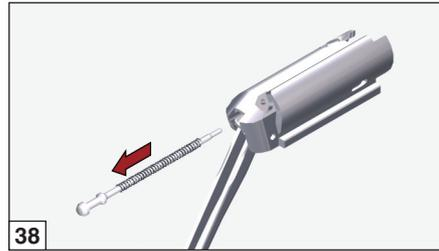

38

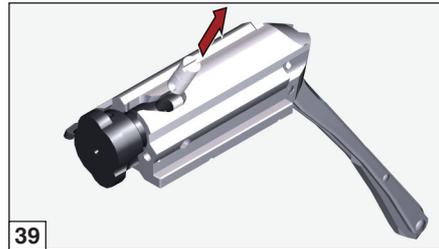

39

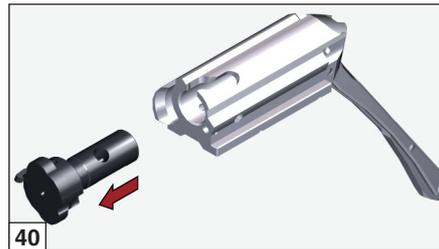

40

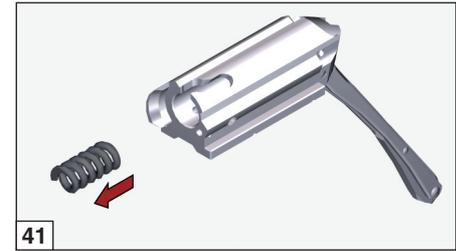

41

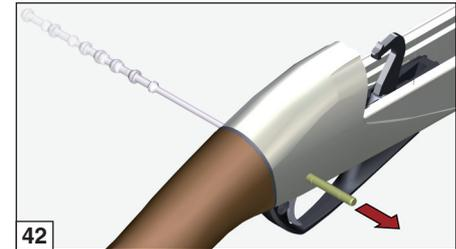

42

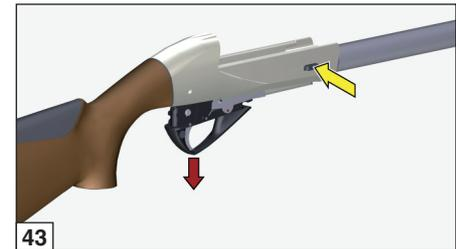

43



Shotgun assembly

For correct assembly after cleaning and maintenance operations, proceed as follows:

- 1) Cock the hammer (fig. 44). Grip the stock-receiver assembly, press the carrier **button** and insert the complete **trigger guard assembly - with the hammer cocked** - into the receiver. Make sure that the front of the trigger guard makes firm contact with the stop (fig. 45).
- 2) Push the trigger guard **pin** into the receiver from the right or left, until it is completely inside (fig. 46).
- 3) Slide the bolt recoil **spring** into its appropriate position (fig. 47).

NOTE: always make sure that the bolt recoil spring is **positioned between the locking head and the bolt itself**, in order to avoid a shot being fired during the closing phase.

- 4) Slide the **locking head** into the bolt, making sure that the **hole** on its stem coincides with the **slot** on the bolt (fig. 48).

WARNING: the slanted surfaces on the locking head's stem should **not be visible** once the bolt locking head is mounted.

- 5) Insert the locking head **pin** in its hole on the locking head's stem, through the slot on the bolt (fig. 49).

NOTE: the **reference line** on top of the pin must be **visible and aligned** with the bolt assembly longitudinal axis (fig. 49).

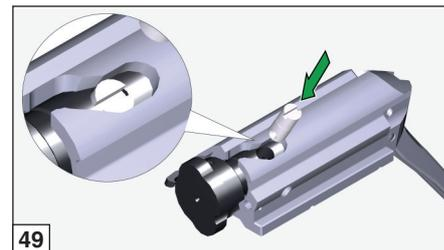
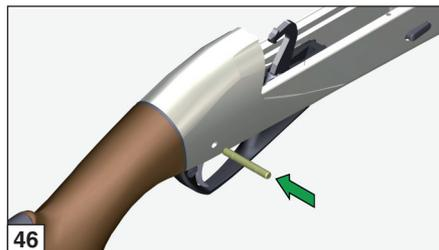
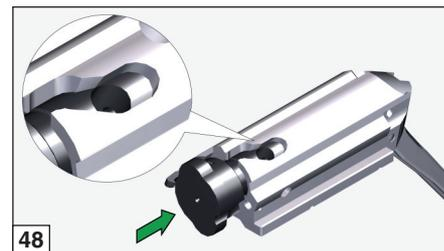
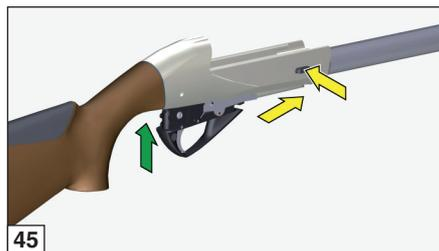
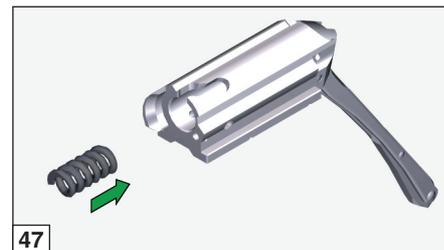
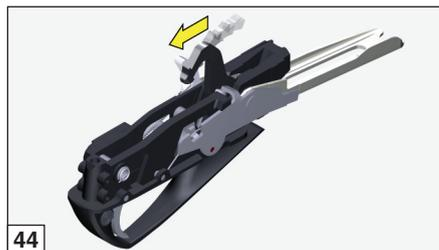



- 6) Insert the firing pin and the firing pin spring inside the bolt hole (fig. 50).

NOTE: **always** make sure that the firing pin spring has been mounted.

- 7) Insert the firing pin **retaining pin** in its seat, so as to block the firing pin (fig. 51).
- 8) Hold the stock receiver assembly almost horizontally and insert the **bolt assembly** in its guide on the receiver (fig. 52).

WARNING: make sure that the **bolt link** slides over the trigger guard assembly, positioning on the recoil spring guide **pin** inside the receiver, once the mounting has been completed (fig. 52).

- 9) Open **the bolt** acting on the locking head frontal part (fig. 53). If the bolt doesn't remain in the opened position, push the cartridge drop lever in the direction shown by the arrow and repeat the procedure.
- 10) Place **the cover** on the receiver next to the bolt (fig. 54).
- 11) While keeping **the cover** adhering to the receiver, move it back sliding it over the bolt until it is fully rested on the receiver back.
- 12) Push **the cocking lever** into its seat hole on the bolt until it fits perfectly (fig. 55).
- 13) **Finish** reassembling the shotgun by repeating all the steps for initial assembly described on page 7 (figs. 7-8-9-10-11).

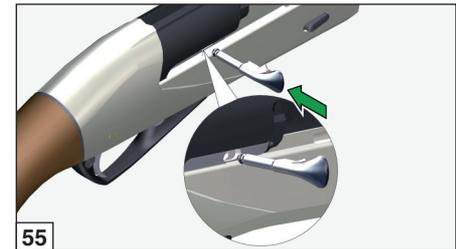
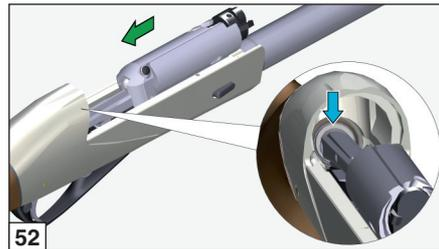
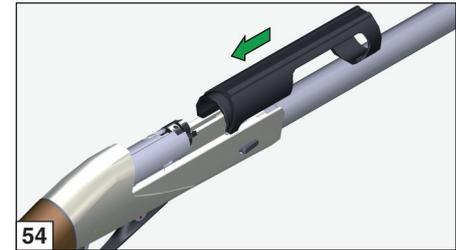
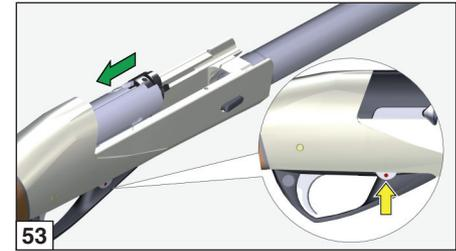
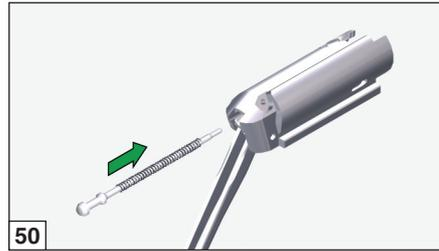

ACCESSORIES AND ADJUSTMENTS

Drop and cast adjustment

Before beginning any operation on your shotgun, always make sure that chamber and magazine have been completely emptied!

(Carefully read loading and unloading instructions).

DROP CHANGE SCHEDULE			
Cast shim (plastic)	Stock locking plate (steel)	Drop shim (plastic)	Drop value at heel (mm)
Reference letter	Reference letter	Reference letter	
DX	Z DX	Z	45 ± 1 DX
SX	Z SX		45 ± 1 SX
DX	A DX	A	50 ± 1 DX
SX	A SX		50 ± 1 SX
DX	B DX	B	55 ± 1 DX
SX	B SX		55 ± 1 SX
DX	C DX	C	60 ± 1 DX
SX	C SX		60 ± 1 SX
DX	D DX	D	65 ± 1 DX
SX	D SX		65 ± 1 SX

Matching instructions: the drop change shims and stock locking plates in the kit are identified by letters. To ensure a correct drop, **always** use plates and shims **with the same letter, e.g.:** C - CDX – for a 60-RH drop or C - CSX – for a 60-LH drop.

DX = Right hand
SX = Left hand

The shotgun is supplied with a “**drop change kit**” (fig. 56) which enables you to adjust the original drop of the shotgun is supplied with.

The kit includes steel **stock locking plates** and plastic **drop change shims** in addition to a pin for fitting a sling attachment (for wooden stocks).

The kit enables you to obtain five different drop patterns (as specified in the table) and two different deflections (right hand or left hand). Each unit is **marked with the corresponding drop and cast letter**.

Determine if your stock drop fits you perfectly, or whether it is either too high or too low for you.

If the stock is too low for you (meaning that the drop is too great), select the adjustment set in reverse alphabetic order (e.g. if the shim fitted in the factory is marked “C”, switch to that marked “B” and to the corresponding stock locking plate).

Proceed as follows to change shims (fig. 57).

1) Unscrew **the two fixing screws** and remove **the butt plate “1”** (using a cross-head screwdriver).

WARNING: to avoid damaging the butt plates, **apply** a light coat of vaseline or grease to the shaft of the screwdriver.

2) **Unscrew the two fixing screws** using a Phillips screwdriver and remove the **comfort kit “2”** from the stock.

- 3) Unscrew **the stock retaining nut “3”** (using a 13 mm hexagon wrench).
- 4) Remove the **nut “3”**, from the recoil spring tube and remove the **rubber washer “4”, stock locking plate “5”, stock “6”, cast shim “7”** and **drop shim “8”**.

WARNING: if the **stock spacer “9”** doesn't remain inside the stock, reassemble it with the seat of **plate “5”** facing the butt plate.

- 5) Assemble **the drop shim “8”** that you have selected onto the recoil spring tube with the **stamped letter** facing the stock.
- 6) Reassemble the selected **cast shim “7”** with the stamped letter (DX or SX) facing toward the stock.
- 7) Point the barrel towards the floor and fit the **stock**. Engage the **stock locking plate “5”** in the stock with the side punched with the chosen letter facing the butt plate.

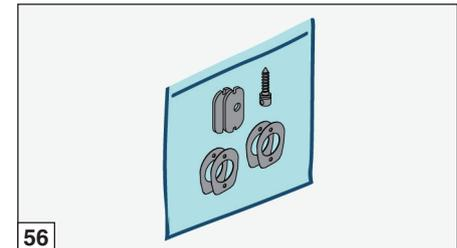



- 8) Fit the **rubber washer "4"** then screw the **nut "3"** on to the end of the recoil spring tube. **Tighten the nut securely.**
- 9) Fit the **comfort kit "2"** inside the stock and secure it with its **two screws** using a Phillips screwdriver.
- 10) Fit the **butt plate "1"** and secure it with its **two screws** using a Phillips screwdriver.

Having altered the stock drop of the shotgun, you have also obviously altered the firing position as well: it is therefore **necessary** that you first practise by executing some shots in order to make sure that the firing position is suitable to your size and shooting style.

WARNING: on completion of the drop change, check that the stock is securely fixed to the receiver. Check again after firing the first few rounds and, if necessary, re-tighten the nut with a suitable wrench to fix the stock securely in place.

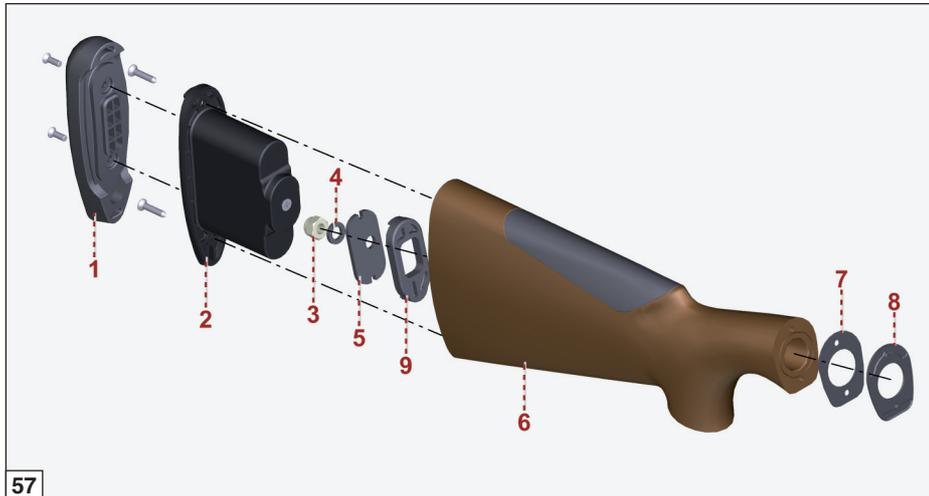

Internal choke

Before starting any operation on your shotgun, make sure that the chamber and the magazine are unloaded!

(Carefully read the instructions on gun loading and unloading).

The barrels with internal chokes are equipped with various types of chokes.

WARNING: before using the shotgun, make sure that the barrel has a choke correctly installed.

NOTE: if correctly installed, internal chokes must not protrude from the barrel's muzzle. Only use Benelli chokes of a length suitable for the choke seat of the barrel.

To change or clean the internal choke, proceed as follows:

- 1) **Unscrew** the internal choke using the special **choke wrench** supplied with the shotgun and extract it completely from the barrel seat (fig. 58).
- 2) If the choke threads become **badly fouled**, clean them with the serrated side of the choke wrench.
- 3) Reassemble the kind of choke required on the barrel seat, taking care to **insert the non-threaded part** inside the barrel; then screw the choke on the barrel thread (fig. 59).
- 4) Complete installation of the choke using the toothed wrench provided (fig. 60).



NOTE: when choke is correctly mounted, it **must not protrude** from the barrel's muzzle (fig. 61).

NOTE: before re-using the shotgun, **make sure that the choke wrench has been removed** from the barrel's muzzle (fig. 62).

Before the shotgun is put away, cleaning the internal choke and relative barrel thread is recommended.

Benelli chokes are marked for an easy identification (fig. 63). Notches on the frontal part of each choke allow a quick recognition, even when the choke is mounted on the shotgun.

NOTCHES	CHOKE	SYMBOL	STEEL SHOT
I	Full	X	NO
I	Full - Steel Shot - OK	X	OK
II	Improved Modified	XX	NO
II	Improved Modified - Steel Shot - OK	XX	OK
III	Modified	XXX	OK
IIII	Improved Cylinder	XXXX	OK
IIII	Cylinder	XXXXX	OK

NOTE: before using steel shot cartridges, make sure that the choke fitted in the barrel is marked "STEEL SHOT - OK" (see table above).

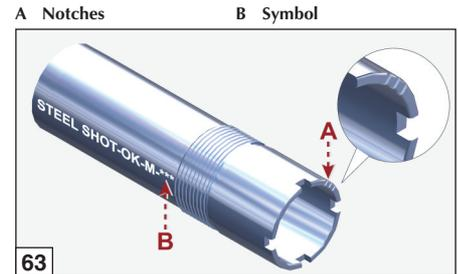
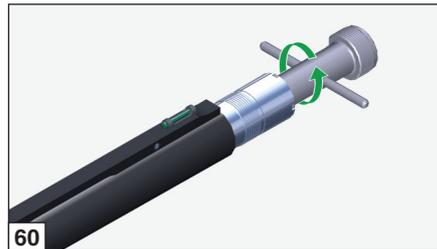
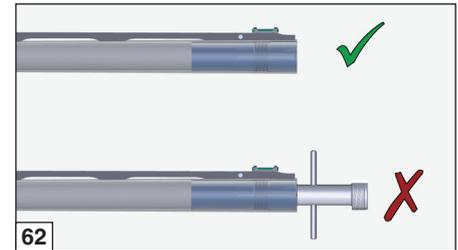
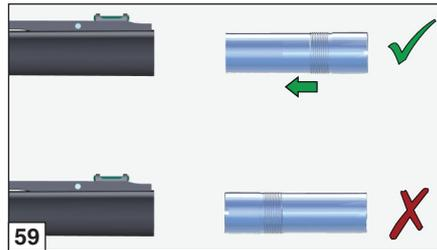
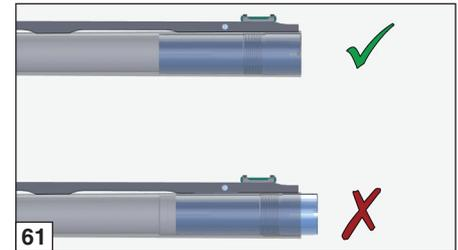
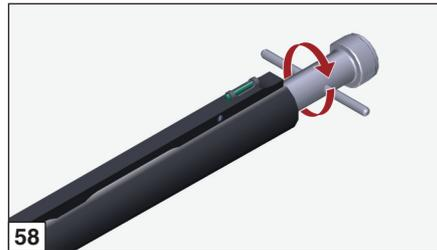



Interchangeable ribs

Before starting any operation on your shotgun, make sure that the chamber and the magazine are unloaded!

(Carefully read the instructions on gun loading and unloading).

The shotgun is fitted as standard with a low, 8 mm wide rib.

The rib can be easily replaced, following the instructions below:

- 1) **Unscrew and remove** the rib fixing screw from the front end of the barrel, near the front sight (fig. 64).
- 2) **Lift and extract** the rib from its seat on the barrel pulling it forward (figs. 65-66).
- 3) Place the required rib, taking care to **properly insert** the housings, then **set** the rib along the barrel for the whole length (fig. 67).
- 4) **Fix** the rib with the fixing screw (fig. 68).

Changing the front sight

On shotguns with a carbon fibre rib, the red fibre optic front sight can be changed for the yellow or green fibre optic sight supplied.

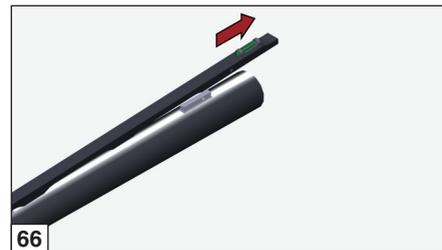

66

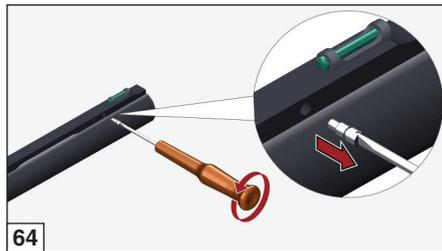

64

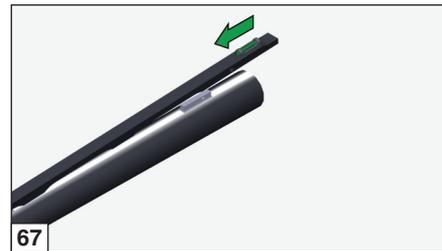

67

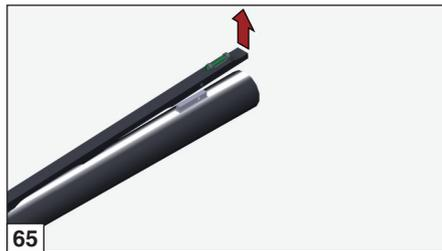

65

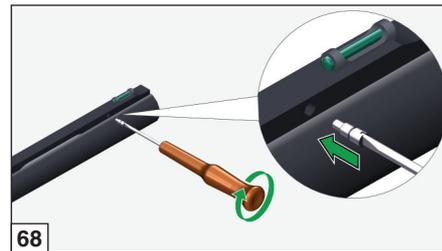

68



Proceed as follows to change the front sight.

- 1) Use the tip of a flat blade screwdriver to prize up the sight mounting and remove it from its seat in the rib (fig. 69).
- 2) Insert the chosen sight into the seat in the rib, pressing hard until it clicks securely into place (fig. 70).

Fitting the sling attachment pin to the stock

Shotguns with wooden stocks come with a sling attachment pin. Proceed as follows to fit this to the stock.

- 1) **Unscrew the two fixing screws using a Phillips screwdriver** and remove the **butt plate "1"** (see fig. 57).

WARNING: smear the tip of the screwdriver with Vaseline or grease to avoid damaging the stock.

- 2) Using the same Phillips screwdriver, unscrew the two fixing screws and remove the **comfort kit "2"** from the stock (see fig. 57).
- 3) Use an Allen key to remove the **rubber plug** from the sling attachment hole inside the stock (fig. 71).
- 4) Using a 3 mm diameter punch as a tommy bar, screw the sling attachment pin into the hole in the stock. Tighten into firm contact with stock, until the hole in the pin lies per-

- pendicular to the line of the stock (fig. 72).
- 5) Fit the **comfort kit "2"** and then the **butt plate** to the stock (see fig. 57).

Removing and changing the comb

Proceed as follows to remove and change the comb.

- 1) **Unscrew the two fixing screws using a Phillips screwdriver** and remove the **butt plate "1"** (see fig. 57).

WARNING: smear the tip of the screwdriver with Vaseline or grease to avoid damaging the stock.

- 2) Using the same Phillips screwdriver, unscrew the two fixing screws and remove the **comfort kit "2"** from the stock (see fig. 57).

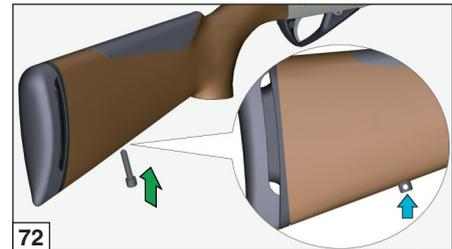
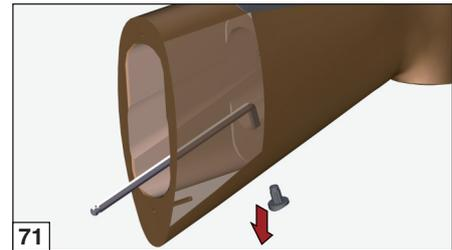



- 3) Insert the tip of a screwdriver through the hole provided in the rear of the stock. Push the bottom of the comb upwards to release its back edge, then lift it and remove it from the stock (fig. 73).
- 4) To fit the new comb, position it so that the two dowels on its underside line up with the holes in the seat on the stock, then push the comb firmly down until it clicks into place (fig. 74).

WARNING: the edges of the comb must mate perfectly with the profile of the stock when correctly fitted.

- 5) Fit the **comfort kit "2"** and then the **butt plate** to the stock (see fig. 57).

Adjusting the rear sight (when fitted)

If the default calibration of the rear sight proves unsuitable, you can adjust for windage and elevation as required.

Before beginning any operation on your shotgun, always make sure that chamber and magazine have been completely emptied! (Carefully read loading and unloading instructions).

Adjusting the rear sight for windage

As for lateral adjustment of the rear sight, proceed as follows (fig. 75):

- 1) Using the supplied key and referring to the graduated alignment notches, adjust the rear sight position into the required direction (move it to the right if you want the point of impact to move right and move it to the left if you want the point of impact to move left).

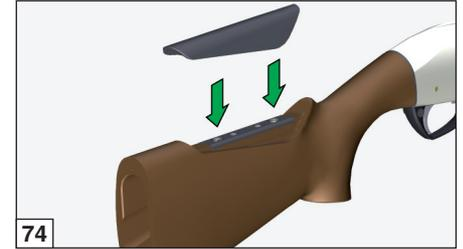

Adjusting the rear sight for elevation

As for rear sight elevation adjustment, proceed as follows (fig. 76):

- 1) Using the supplied key and referring to the relative graduated alignment notches, adjust the rear sight position into the required direction (move it upwards if you want to raise the point of impact, or move downwards if you want the point of impact to be lower).

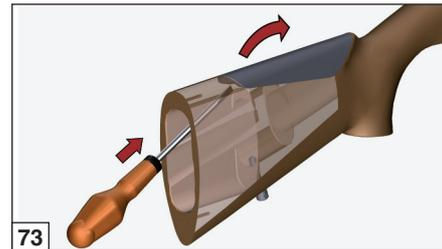
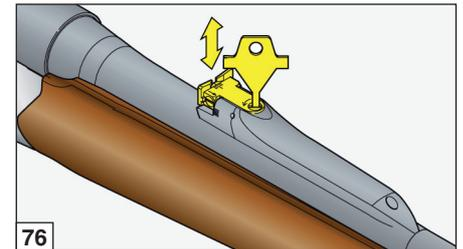
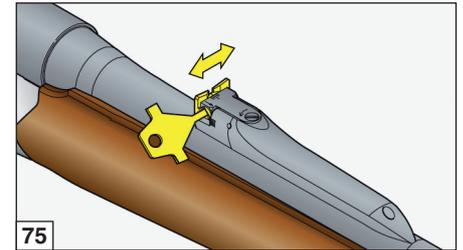

73

76



Spare Parts



To order spare parts you must specify the gauge, the model and the serial number of your shotgun.

Part numbers here listed refer to respective drawings.



Drawing 1

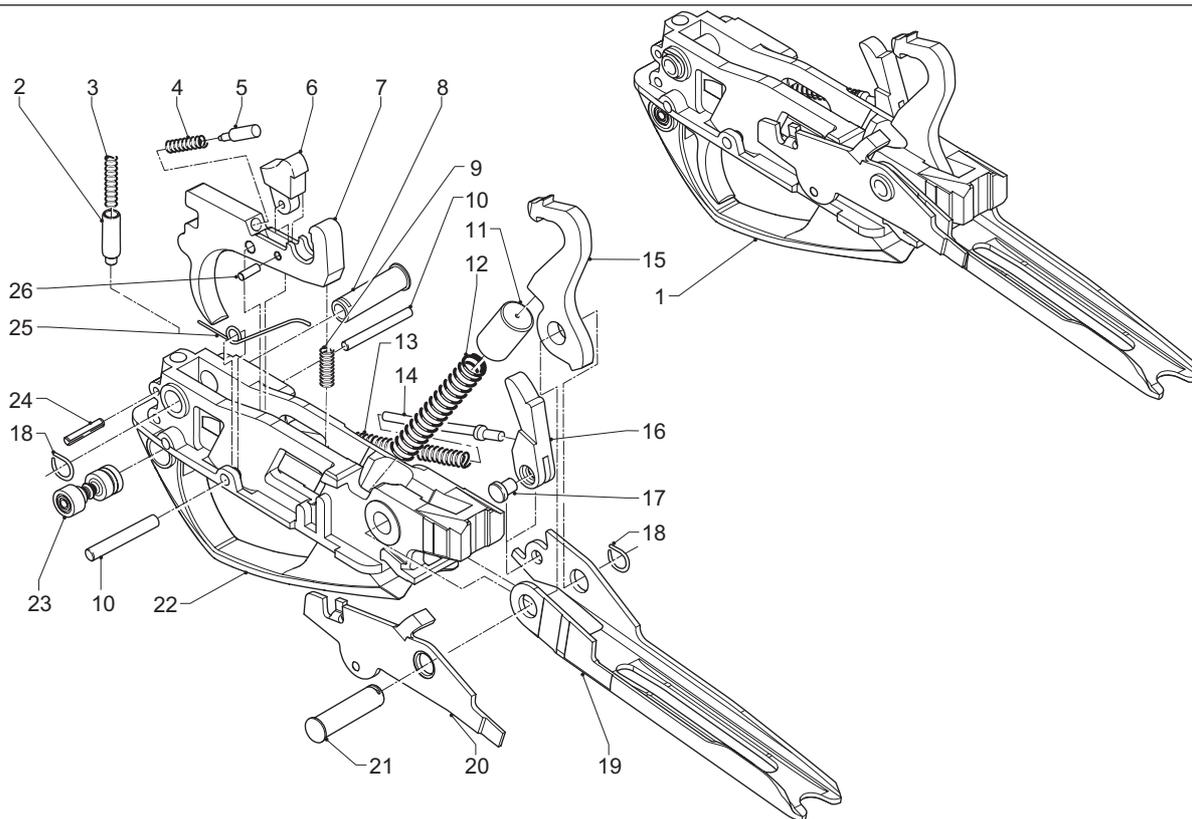



Pos. No.	Code	Description
1	001H	Trigger guard assy
2	008A	Plunger
3	007A	Spring
4	277J	Spring
5	045J	Pin
6	005B	Disconnecter
7	009B	Trigger
8	016H	Pin bush
9	011J	Spring
10	010L	Trigger pin
11	003A	Cap
12	004A	Spring
13	021J	Spring
14	022A	Pin
15	002B	Hammer
16	019A	Stop tooth
17	020A	Pin
18	018A	Spring
19	017H	Carrier
20	076H	Cartridge drop lever
21	097H	Pin
22	014H	Trigger guard
23	013C	Safety button
24	006P	Retaining pin

Pos. No.	Code	Description
25	077B	Spring
26	023A	Pin





Drawing 2

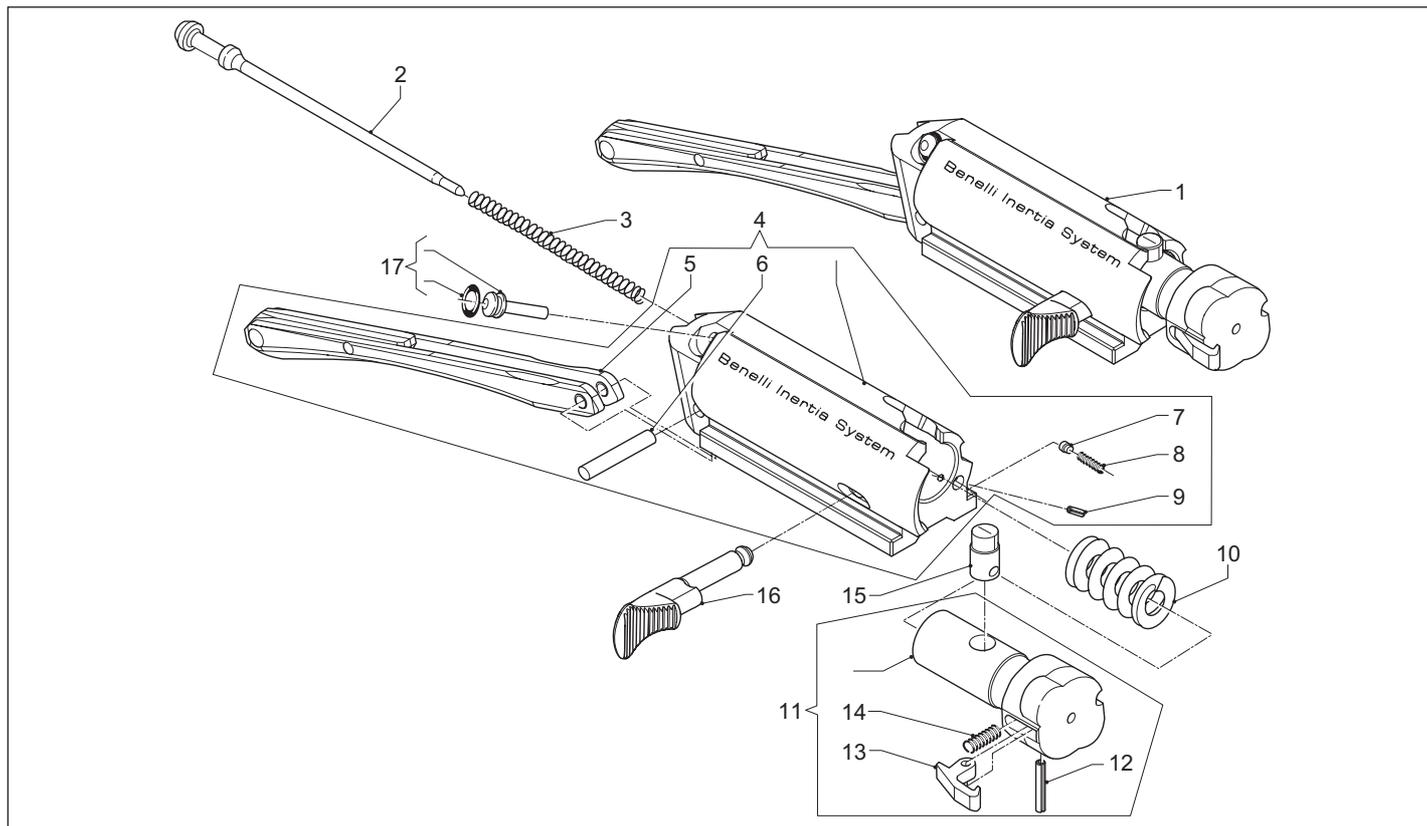



Pos. No.	Code	Description
1	024H	Bolt assy
2	025B	Firing pin
3	037A	Spring
4	026H	Bolt, partial
5	027L	Link
6	029J	Link pin
7	039A	Pin
8	038J	Spring
9	040A	Pin
10	036A	Spring
11	165H	Locking head assy
12	035A	Pin
13	034A	Extractor
14	033J	Spring
15	031B	Locking pin
16	030H	Bolt handle
17	028A	Retaining pin

Pos. No.	Code	Description
----------	------	-------------





Drawing 3

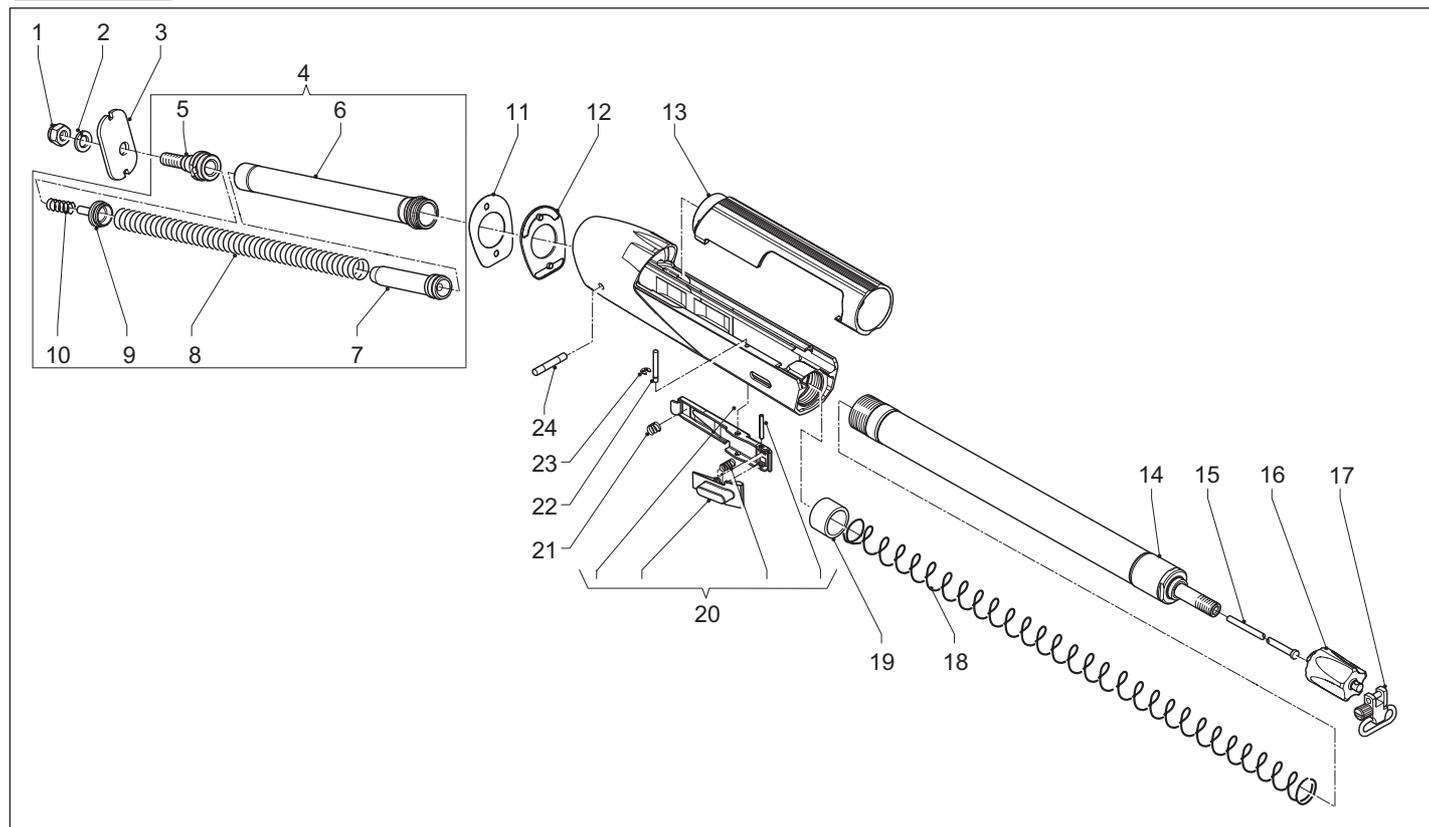



Pos. No.	Code	Description
1	053A	Nut
2	052A	Elastic washer
3	150W	Locking plate
4	166H	Recoil spring tube assy
5	050H	Nut screw
6	K049	Recoil spring tube
7	055H	Pin
8	054D	Spring
9	482H	Pin
10	274J	Spring
11	286H	Cast shim
12	147H	Drop shim
13	098H	Cover
14	066B	Magazine tube
15	067A	Shot plug
16	146H	Fore-end follower
17	188L	Removable sling swivel
18	064A	Spring
19	065G	Magazine follower
20	057H	Carrier latch assy
21	058J	Spring
22	156H	Pin
23	302H	Circlip
24	015H	Pin

Pos. No.	Code	Description
----------	------	-------------





Drawing 4

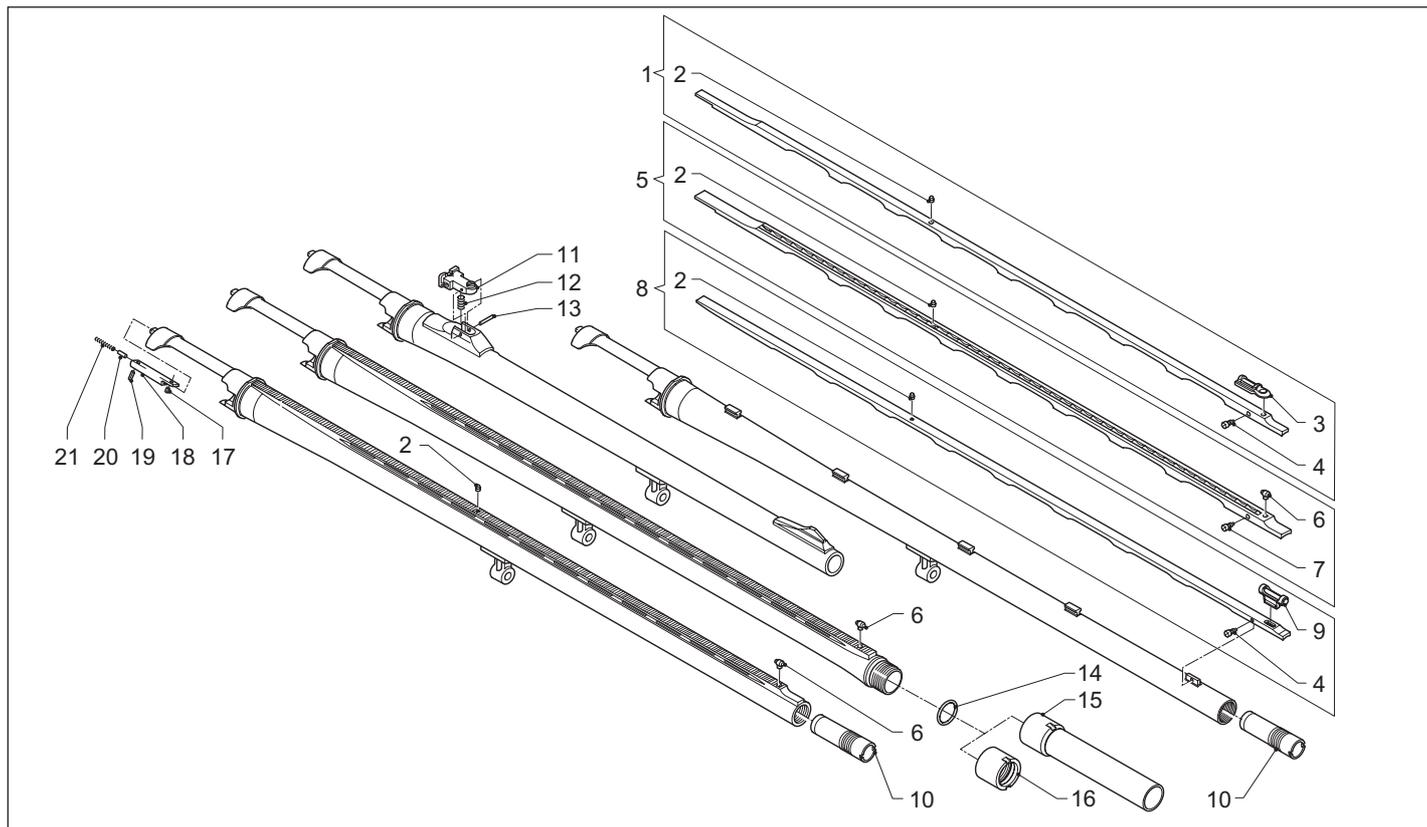



Pos. No.	Code	Description
1	199L	Hunting high rib barrel
2	153A	Intermediate sight
3	044Y	Front sight
4	184L	Screw
5	200L	Shooting rib barrel
6	044B	Fluorescent front sight
7	185L	Screw
8	201H	Hunting low rib barrel
9	044H	Fibre optic front sight
10	213G	Internal choke
11	127N	Rear sight
12	259N	Spring
13	035A	Fixing pin
14	492B	O-Ring
15	490B	External choke
16	491B	Ring nut
17	172j	Retaining rivet
18	168j	Ejector frame (2" 3/4 chamber)
18	168j	Ejector frame (3"- Magnum chamber)
19	047j	Pin
20	045j	Ejector pin
21	046j	Spring (2" 3/4 chamber)
21	046j	Spring (3"- Magnum chamber)

Pos. No.	Code	Description
----------	------	-------------





Drawing 5

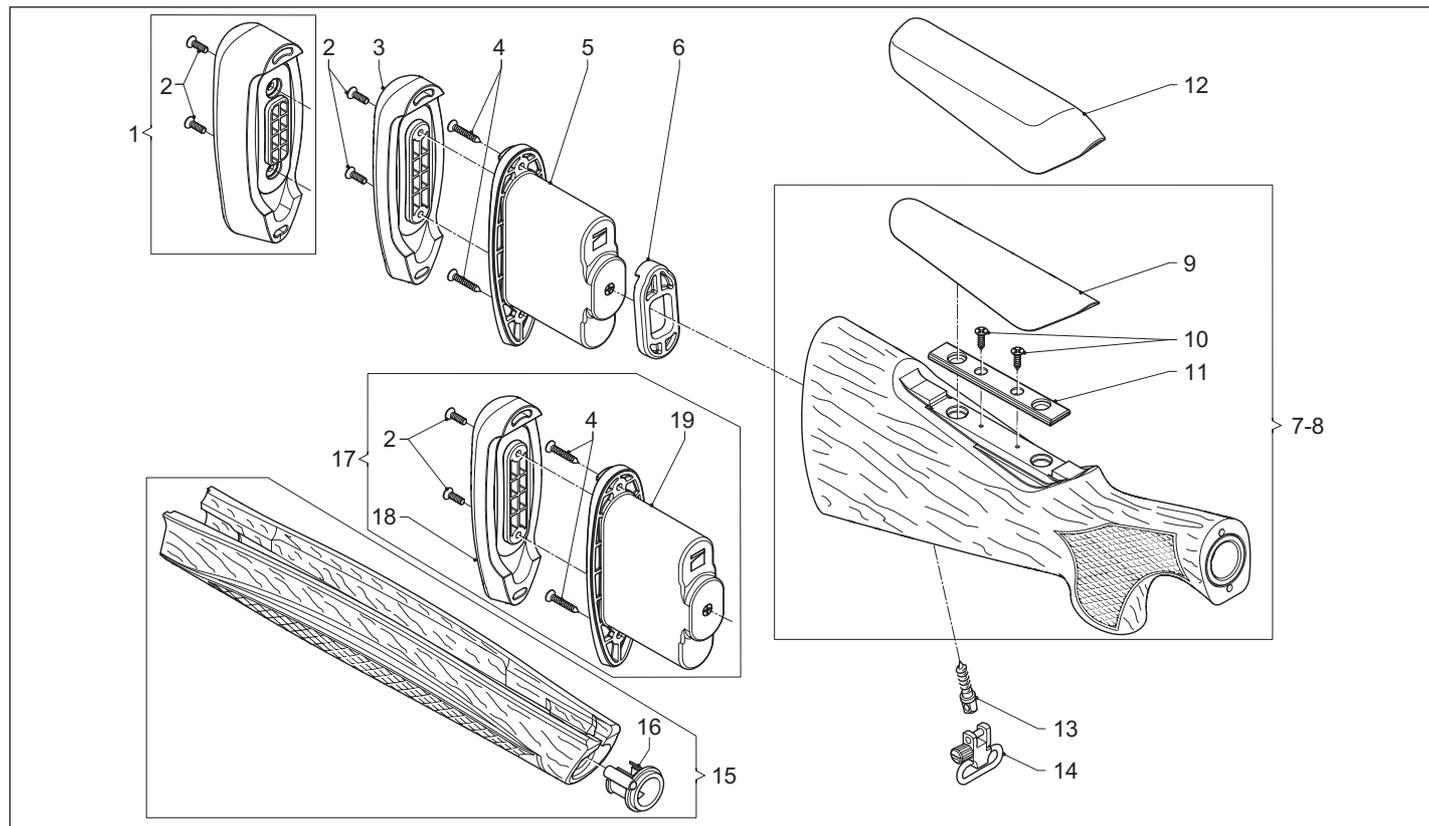



Pos. No.	Code	Description
1	203H	Polyurethane recoil pad kit LOP 380 mm
2	129F	Screw
3	151H	Polyurethane recoil pad LOP 365 mm
4	485H	Self-tapping screw
5	486H	Stock end case LOP 365 mm
6	149H	Shim
7	381H	Stock assy LOP 365 mm
8	381H	Stock assy LOP 350 mm
9	380H	Polyurethane comb, low
10	484H	Self-tapping screw
11	483H	Comb base plate
12	457H	Gel comb, tall
13	152C	Screw
14	188L	Removable sling swivel
15	070H	Fore-end (wood) assy
16	167H	Fore-end lock ring
17	489H	Complete Comfort kit LOP 350 mm
18	488H	Polyurethane recoil pad LOP 350 mm
19	487H	Stock end case LOP 350 mm

Pos. No.	Code	Description
----------	------	-------------

